

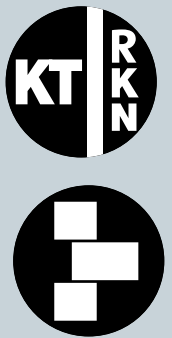

Hahn KT-RKN

- D** Universelles Rollenband für Kunststofftüren
- F** Paumelle cylindrique universelle pour portes PVC
- GB** Universal butt hinge for PVC-U doors



Einbauanleitung · Notice de montage · Installation instructions



Einzelteile · Pièces détachées · Single Parts

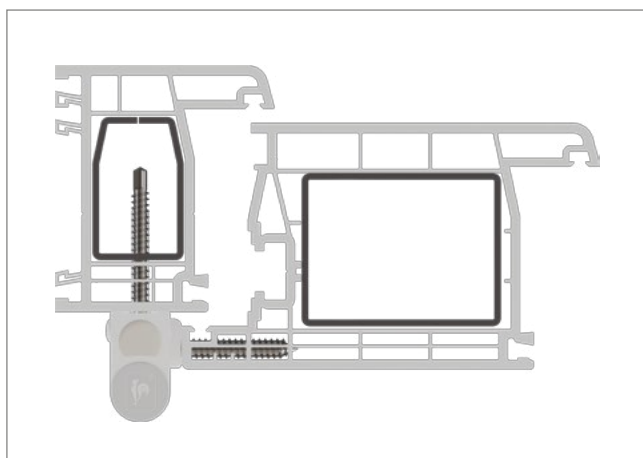
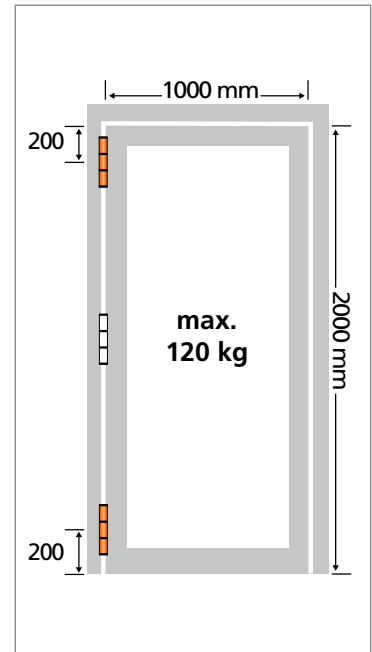

Lagerbuchse aus wartungsfreiem Kunststoff – **keinesfalls schmieren!**

Douille en matière plastique ne requérant aucun entretien – **ne graisser en aucun cas !**

Bearing bushes made of maintenance-free PVC – **do not lubricate!**

Montage des Türbands · Montage de la paumelle · Installing the hinge

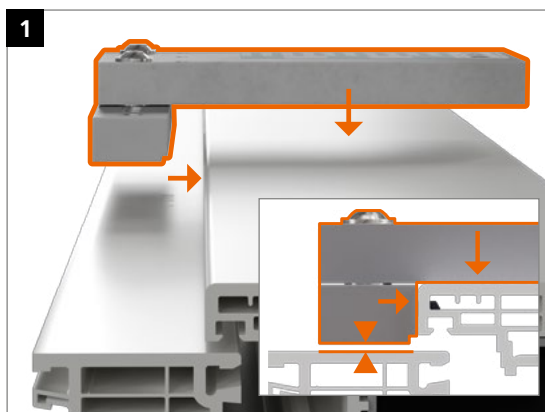

Montage des Türbands · Montage de la paumelle · Installing the hinge

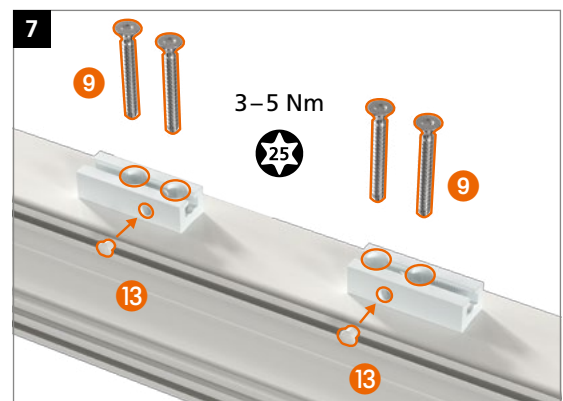
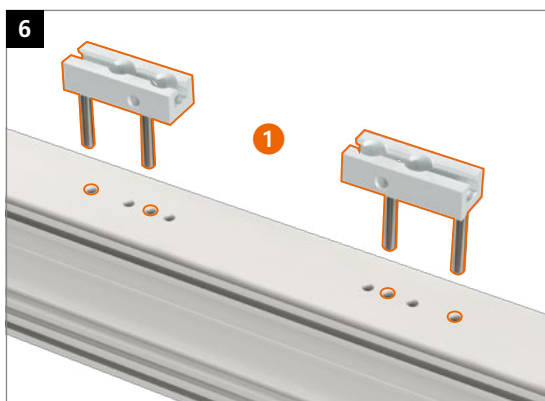
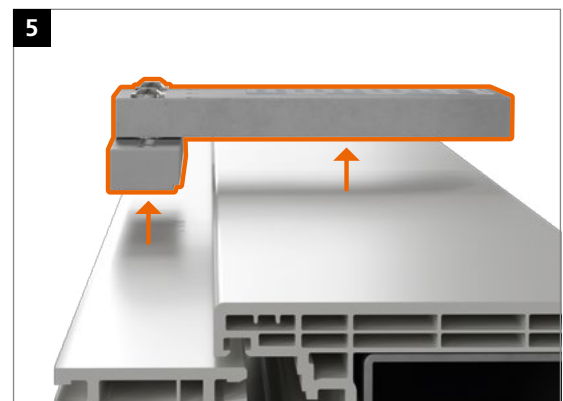
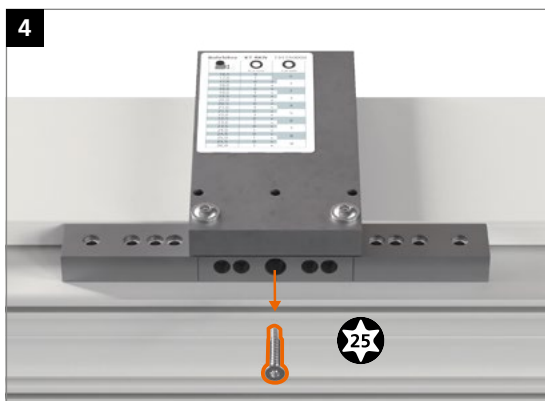
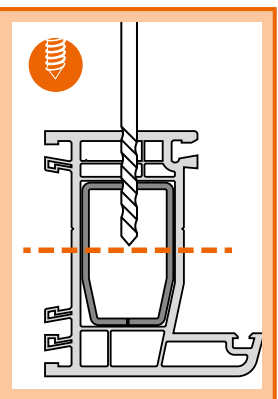
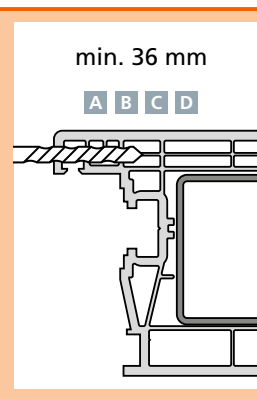
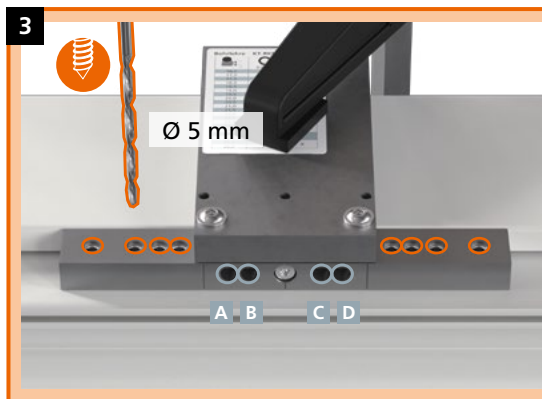
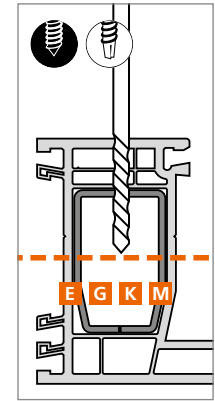
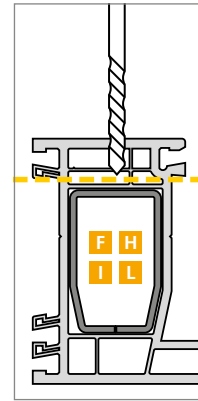
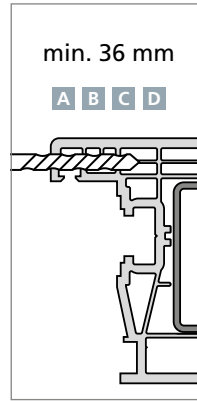
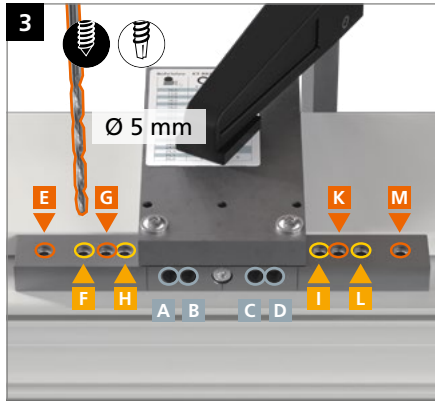

Montage des Türbands · Montage de la paumelle · Installing the hinge

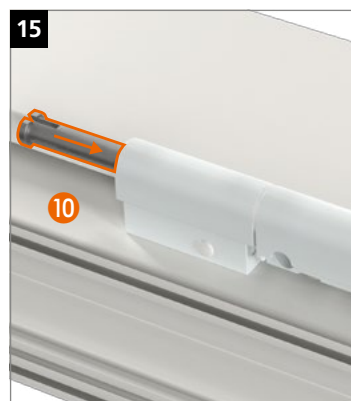
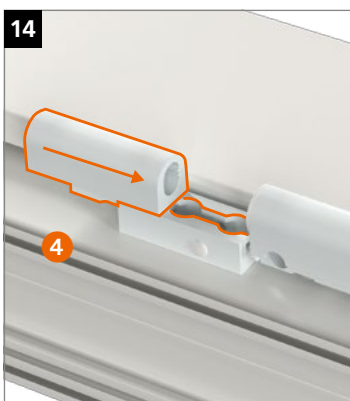
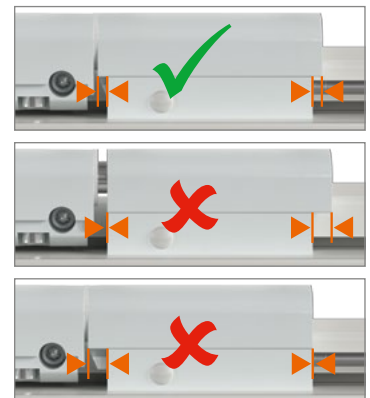
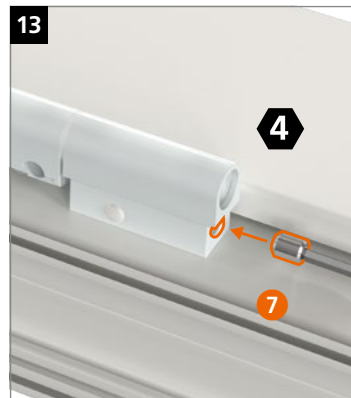
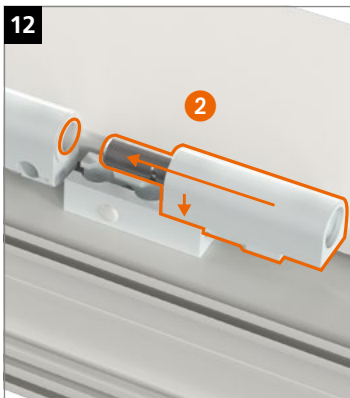
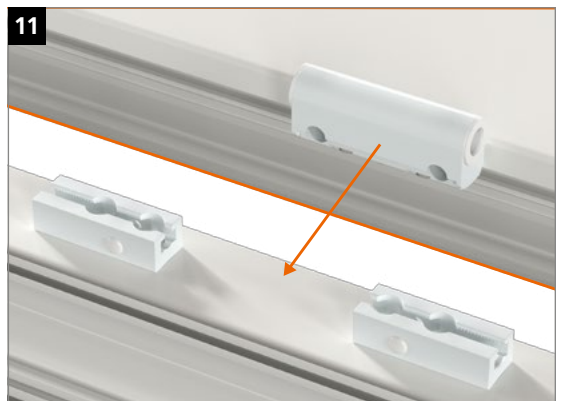
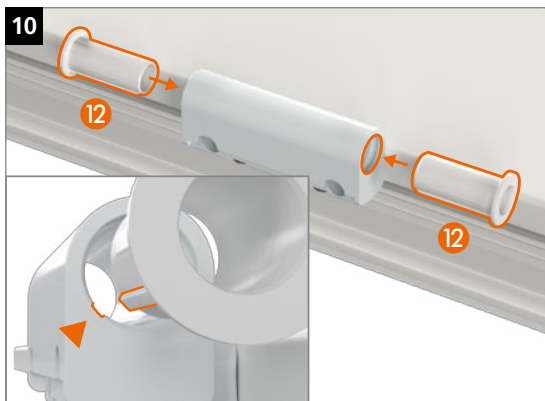
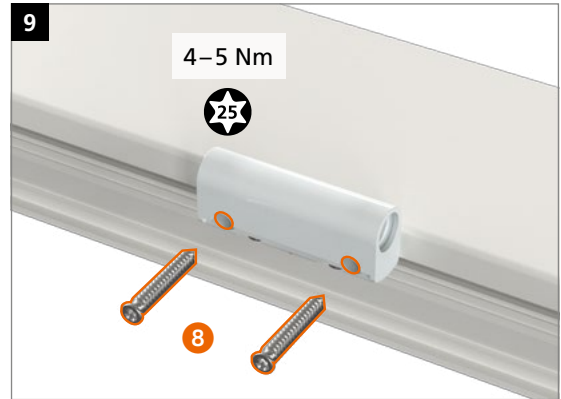
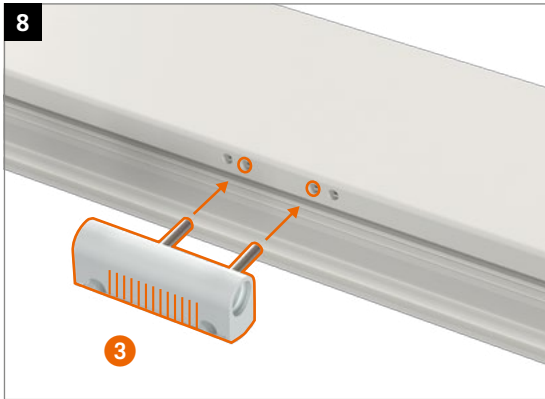

Montage des Türbands · Montage de la paumelle · Installing the hinge

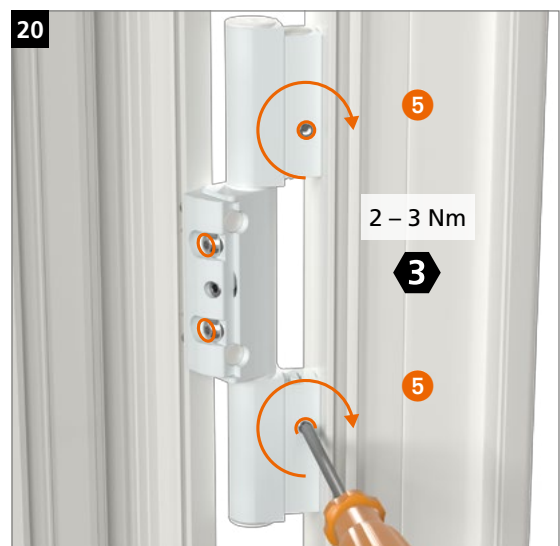
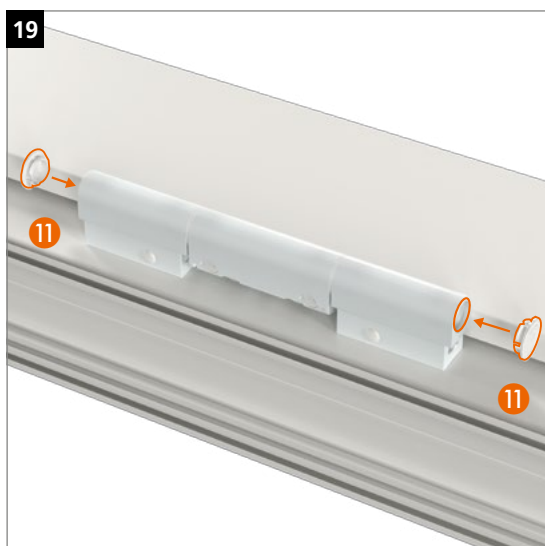
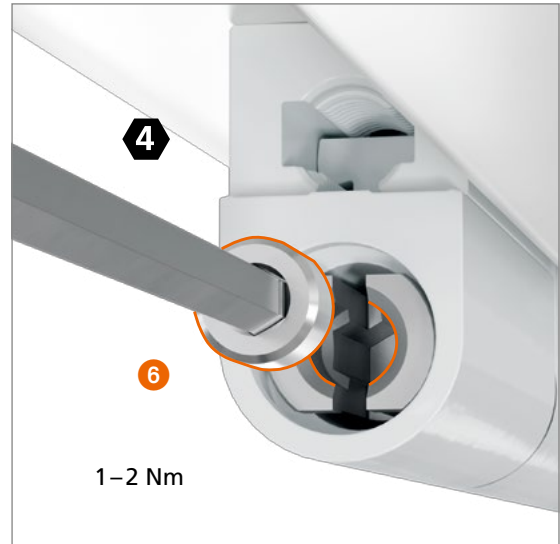

Einstellanleitung
Notice de réglage
Adjustment instructions

Verstellung der Bänder nur durch im
 Türenbau erfahrene Fachhandwerker.

Réglage et montage des paumelles
 uniquement par des professionnels qualifiés.

Adjustment and regulation only to be
 done by an experienced tradesman.



Höhenverstellung · Réglage en hauteur · Adjusting the height

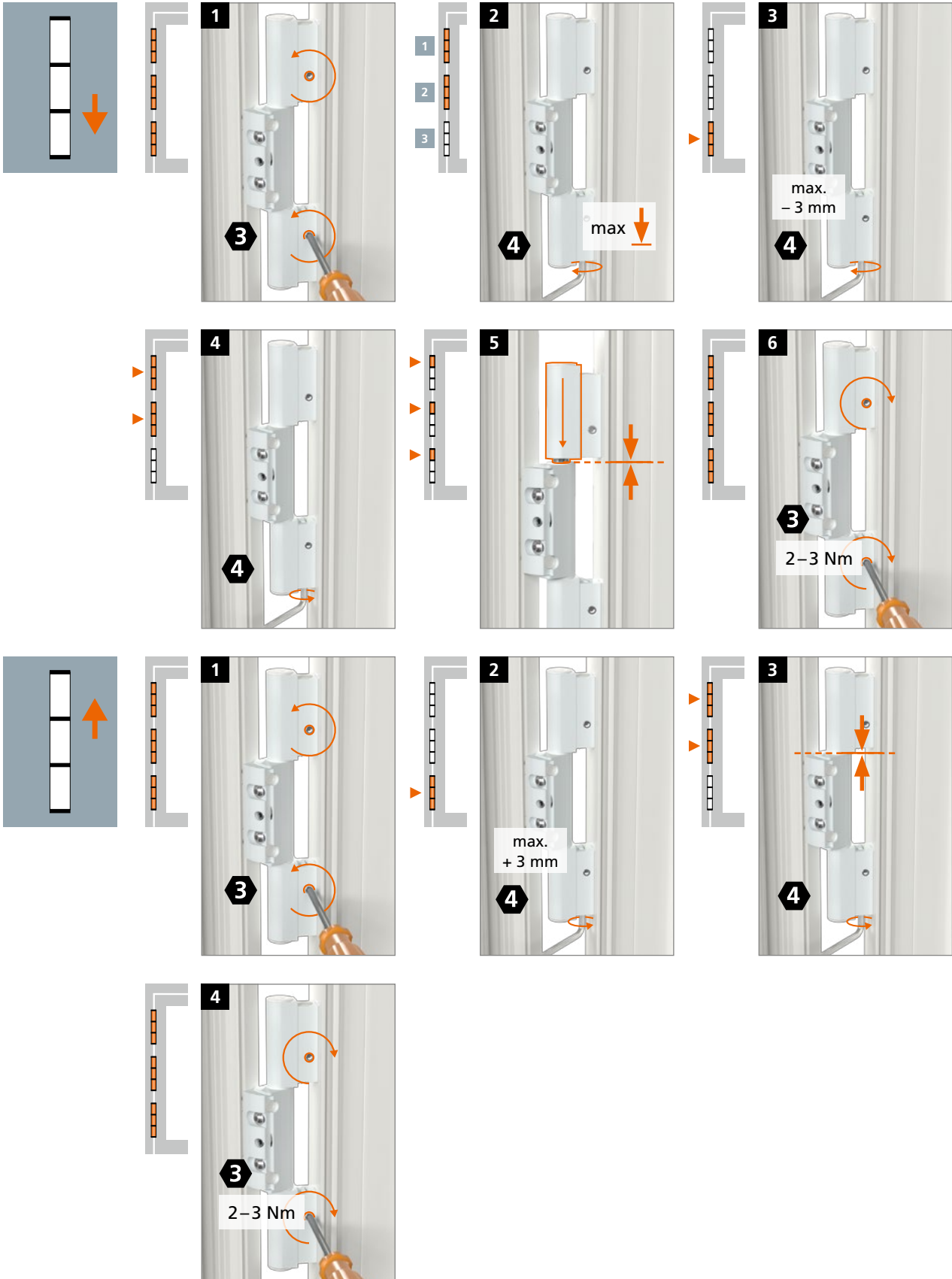

Einstellanleitung
Notice de réglage
Adjustment instructions

Verstellung der Bänder nur durch im
 Türenbau erfahrene Fachhandwerker.

Réglage et montage des paumelles
 uniquement par des professionnels qualifiés.

Adjustment and regulation only to be
 done by an experienced tradesman.



Horizontalverstellung · Réglage horizontal · Horizontal adjustment

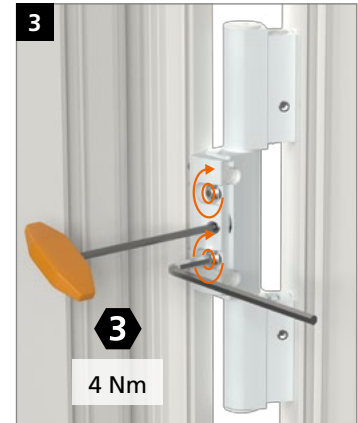
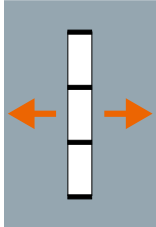

Dichtungsdruckverstellung · Réglage de la compression du joint d'étanchéité · Adjusting the sealing pressure

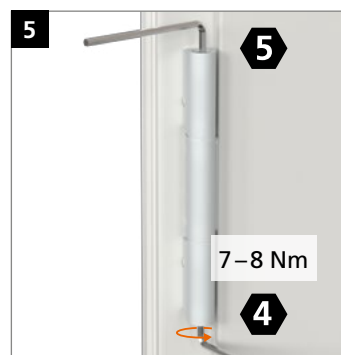
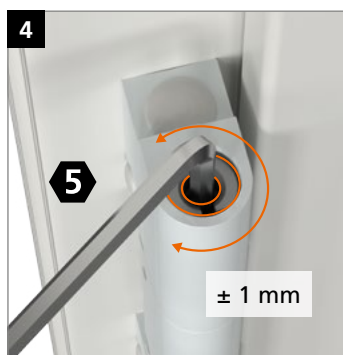
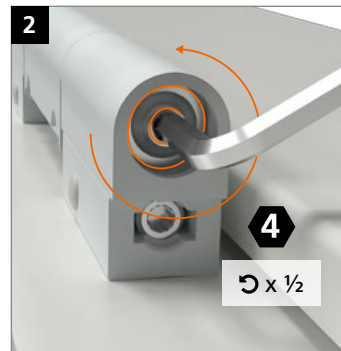
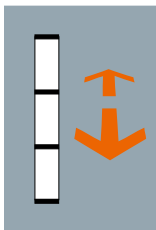

Einstellanleitung
Notice de réglage
Adjustment instructions

Verstellung der Bänder nur durch im
Türenbau erfahrene Fachhandwerker.

Réglage et montage des paumelles
uniquement par des professionnels qualifiés.

Adjustment and regulation only to be
done by an experienced tradesman.



Demontage an der Baustelle · Démontage sur le chantier · Disassembly on site

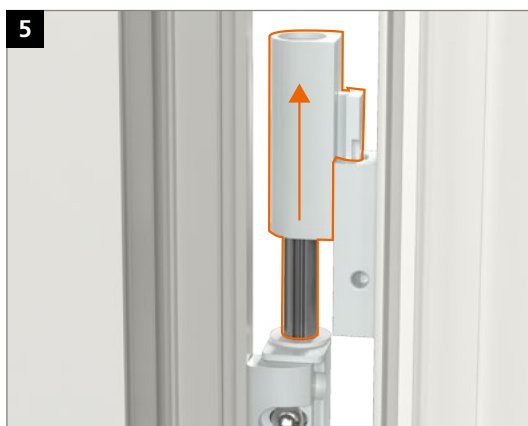
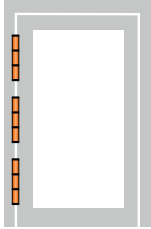

EBA KT-RKN 3-teilig D/F/GB/D-EBA0204/03.21/Technische Änderungen vorbehalten. Sous réserve de modifications techniques. Right to alter technical details reserved.

